

FREAK ATHLETE

Pro Upgrade Kit Assembly Guide

Important Notice

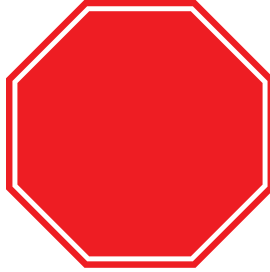

The written instruction manual is meant to be a supplement to the Pro Upgrade Kit Assembly video and Getting Started Video.

Go to FreakAthlete.co/ProUpgradeKitGuide for full video instructions.

It is critical to follow the full Assembly Video and the Getting Started video for your own safety.

FREAK ATHLETE

Pro Upgrade Kit Assembly Guide



[Pro Upgrade Kit
Assembly](#)



[Pro Upgrade Kit
Getting Started](#)

FREAK ATHLETE

Pro Upgrade Kit Assembly Guide

What's Included		
Bolts	Washers, Nuts, & Other	Tools
● 4x M10x70 Bolts	● 9x M10 Washers ● 5x M10 Nuts	● 2x Hex Wrenches

⚠ IMPORTANT NOTE For **video assembly**, go to FreakAthlete.co/ProUpgradeKitGuide
Make sure all screws are **fully tightened** during assembly.

Pro Upgrade Kit Assembly Parts
● Rear U Base ● Wheels ● Back Extension Pro Pads ● Nordic Pro Pads ● New Vertical Storage Bar



Steps 1: Reinstalling Back Frame

Hardware & Parts

1. **IMPORTANT:** Make the machine in full flat mode to ease the process of upgrading the unit.
2. Remove exiting Rear Base by taking off two bolts completely.
3. Place the machine on top of Rear Base to have ample amount of room for preparation in attaching the Rear U base.

● Wrench (provided)

Flat Mode

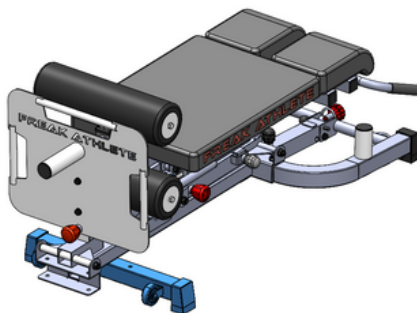
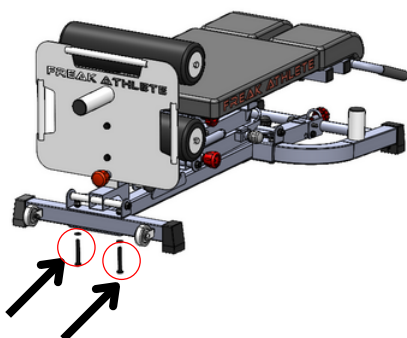
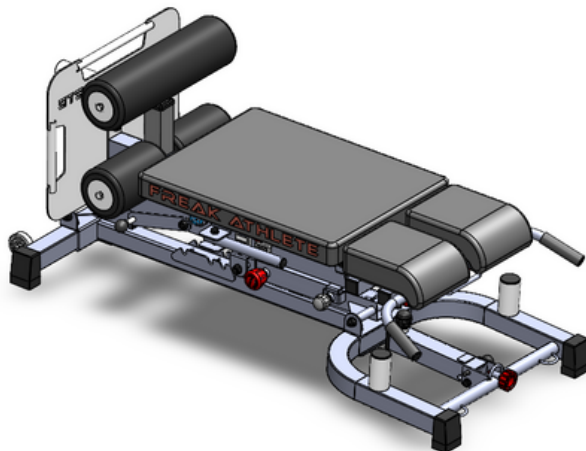

Steps 2: Installing Rear U Base Wheels

Hardware & Parts

1. IMPORTANT:

*For V1 Nordic Hyper (Red or Black Knobs)

-Use the bottom hole on the left to fix the wheel.

*For V2 Nordic Hyper (Colorful knobs)

-Use the Top hole on the left to fix the wheel.

2. Place the Bolts & Washers into the base frame on the left and right side, then grab the one set of wheels and flush it against the base frame. Then fix it with the nuts and hand tighten.

3. To properly tighten the screw use the tools provided and repeat the process on the other side.

- Wrench (provided)
- 4x M10x70 Bolts
- 8x M10 Washers
- 4x M10 Nuts
- Rear U Base
- Wheels

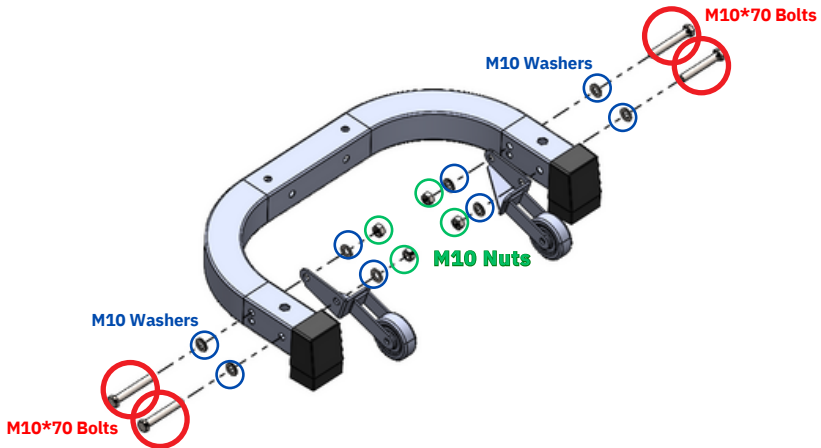

*Important

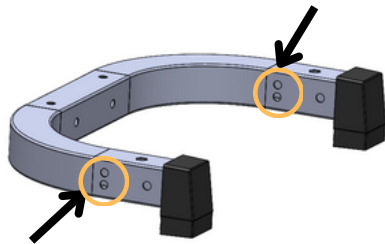

Steps 3: Installing Rear U Base

Hardware & Parts

1. Attach the Rear U Base to the Main frame using two existing M10*75 Bolts, four M10 Washers and two M10 Nuts
2. Make sure that the feet of the Rear U Base is facing down before connecting to the Main Frame.

- Wrench (provided)
- 2x M10x75 Bolts
- 4x M10 Washers
- 2x M10 Nuts
- Rear U Base



M10x75 Bolts



M10 Washers



M10 Nuts

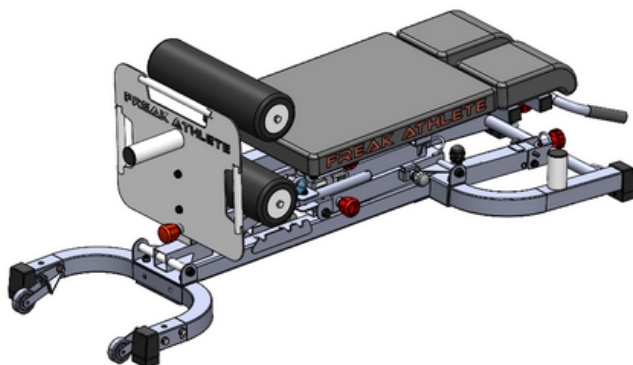
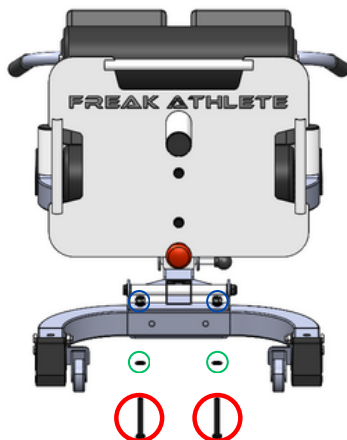

Steps 4: Installing Back Extension Pro Pads

Hardware & Parts

1. Make the Nordic Hyper in 45 degree angle.
2. Unscrew the bolts and knobs on existing Back Extension Pads and reuse it to fix the Pro Pad in place.
3. Important Notice: Some orders will come with the washers built in to the spacers. If this is the case, then you will need only 4 washers. If this is not the case, then you will need 6 washers.

- 2x M10*60 Bolts
- 2x Red Adjustment Knobs
- 6x M10 Large Washers
- 2x Plastic Spacers
- Back Extension Pro Pads

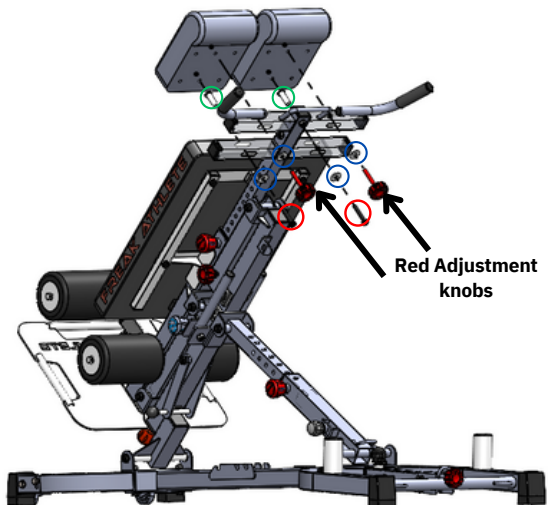
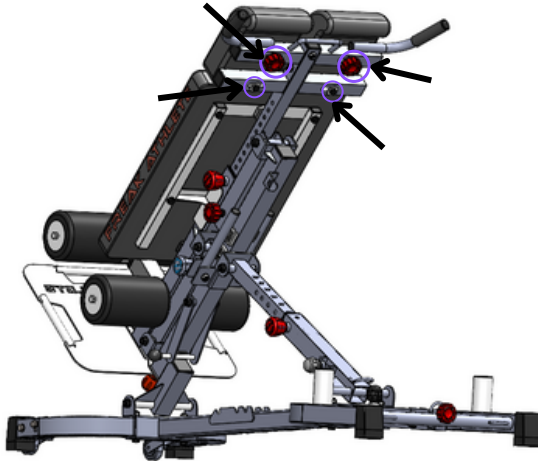

Steps 5: Replacing Nordic Pad with Pro Pad

Hardware & Parts

1. Make the Nordic Hyper in Flat mode and take off the Nordic Pad.
2. Remove the four 10x45 Bolts and four M10 Washers and switch the frame from old Pad to Pro Pad.
3. Once fully hand tightened, take your wrench and fully tighten.

- Wrench (provided)
- 4x M10*45 Bolts
- 4x M10 Washers

Nordic Pro Pad

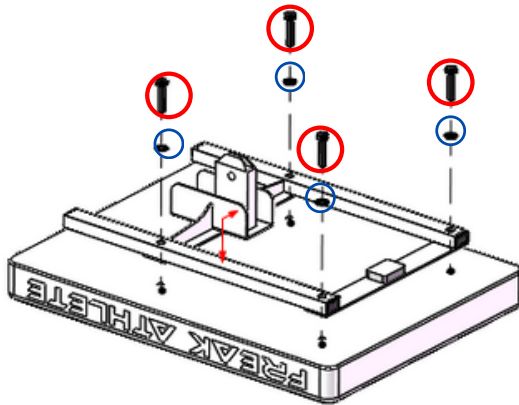
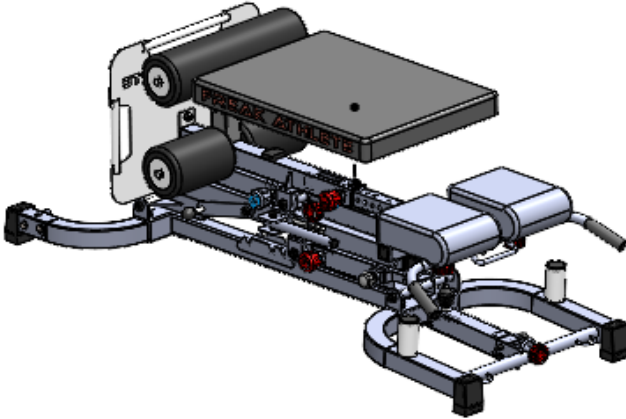

 M10x45 Bolts

 M10 Washers

Steps 6: Installing Vertical Storage Bar

Hardware & Parts

1. Remove top loading bar by taking off the bolt completely. Then also remove the next bolt below it.
2. Grab your New Vertical Storage Bar then pull down and keep lifting until clicks in to upright and angled position.

Important: Make sure the Vertical Storage Bar will always facing up.

3. Place the first M10x25 Bolt on top most hole and line it up with the top hole of Vertical Storage Bar, then add the washer and nut on the other side and hand tightened it. Repeat the Process on to the next bolt.
4. Take your wrench to fully tighten them down.

- Wrench (provided)
- 2x M10*25 Bolts
- 2x M10 Nuts
- 4x M10 Washers

New Vertical Storage Bar

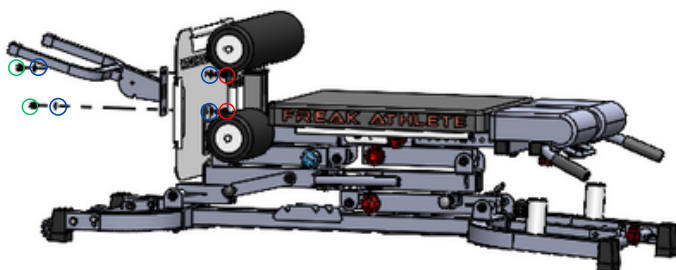
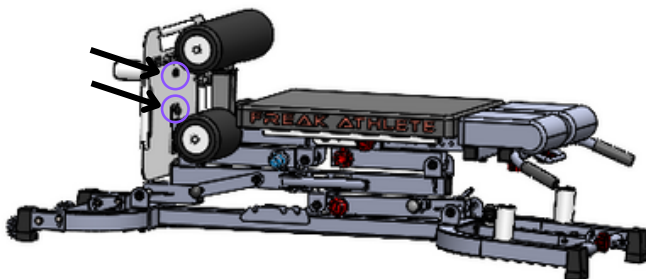

⚠ IMPORTANT NOTE

Ensure all knobs are tightened when in use to ensure stability.



To learn **how to use** your Nordic Hyper, go to **[FreakAthlete.co/HyperGuide](https://www.freakathlete.co/HyperGuide)**